

Drill Press Notes

Requirements:

Proper eye protection must be worn—operate only with instructor's permission and after proper instructions have been received.

1. Always use a piece of scrap wood and set the table or stop to keep from drilling into the tabletop.
2. Use a clamp or vise grips to secure/fasten your wood to the table.
3. Make sure that your scrap wood, good wood, and any clamp you are using are the ONLY objects on the table. Other objects can get caught in the machine and cause injuries.
4. Use a "V-block" clamp for CO₂ cars, round or irregular shaped stock.
5. Select the right size and type of bit. Wood bits for wood; metal bits for metal.
6. Use a center punch for a guide whenever possible. Always use a center punch when drilling into metal or hard woods.
7. Do not panic if the bit gets stuck in the wood. Turn the machine off. When it has completely stopped, remove the bit from your wood.
8. Select the correct drilling speed. For metal or hard woods and large drill bits you should use a slower speed.
9. Always remove the chips from the table after the machine is turned off and is no longer moving. Use a table brush, never your hands.
10. As with any machine, if it is not working properly you should always turn it off, unplug it, and tell a teacher.

Drill Press Parts

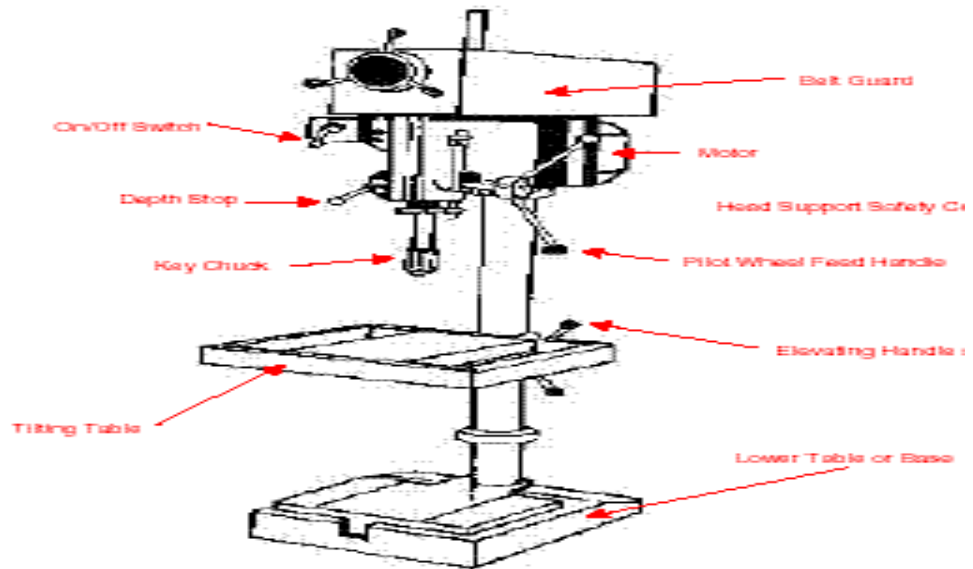

Drill Press Written Test

Use the correct heading and write the answers on your own paper. Use the BEST answer to complete the following:

1. You (**Should** **Should not**) use a piece of scrap wood and a clamp or vise grip when using the drill press.

- 2/3. Objects other than your wood and clamps (**Should** **Should not**) be removed from the table top because they can _____

4. Use a (**C-Block** **V-Block**) to clamp down C02 cars and irregular stock.

5. The type of bit you select for drilling (**Is** **Is not**) important.

6. You (**Should** **Should not**) use a center punch when drilling into metal or hard woods.

7. You should use a (**Faster** **Slower**) drill speed when drilling into metals, hard wood, and with larger drill bits.

- 8/9. (**Do** **Do not**) **panic** if the bit gets stuck in the wood, you should:

10. You should remove chips from the table with your (**Hand** **Table broom**).

11. As with any machine, if it is NOT working properly you should: _____

List five safety procedures you should do before you operate this machine:

12. _____
13. _____
14. _____
15. _____
16. _____

Drill Press Written Test Key

1. Should
2. Should
3. Get caught in the machine, thrown, and cause an injury.
4. V-Block
5. Is
6. Should
7. Slower
8. Do not
9. Turn it off and carefully remove the drill bit and get help if you need it.
10. Table broom
11. Turn it off, unplug it, and tell the teacher.

List five safety procedures you should do before you operate this or any machine:

1. Tuck in your shirt.
2. Secure your hair.
3. Remove jewelry.
4. Wear Z87 safety glasses.
5. Work with a partner.
6. Listen for and report any problems immediately.
7. Make sure that all guards are in place and working.
8. No horseplay.
9. Keep work area clean.
10. Protect hands.